



特殊ダイヤモンド各種

■特長

●形状・サイズ・ダイヤモンド粒度・ダイヤモンド長とも豊富に取り揃えました。様々なワークに対応できます。
特殊形状の製作も可能ですので、ご用命下さい。

■ダイヤモンド粒度

●グリップ色の違いにより、作業中のダイヤモンド粒度識別が容易です。

■Use : Various kinds of SHAPES, DIMENSIONS and DIAMOND GRID NUMBERS(#) are combined to polish the surfaces of the hardened Metals and Ceramics in works. Furthermore, TSUBOSAN accepts the customer's special order with a will. According to each difference of Grip Color, a worker can distinguish each roughness of Diamond File during his work.

	紫 (PURPLE)	#100	
	青 (BLUE)	#150	
	赤 (RED)	#200	
	緑 (GREEN)	#300	
	黄 (YELLOW)	#400	
	黒 (BLACK)	#600	

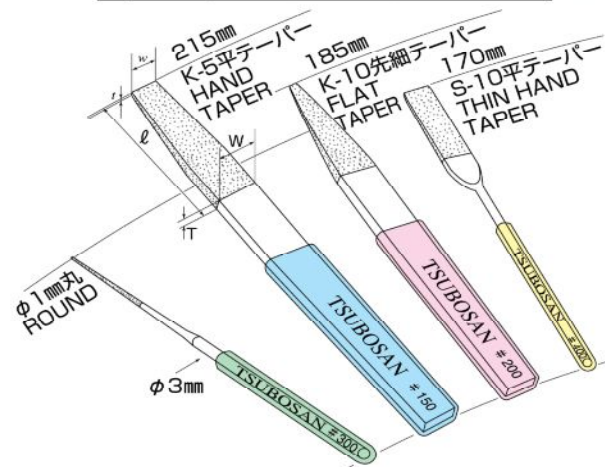
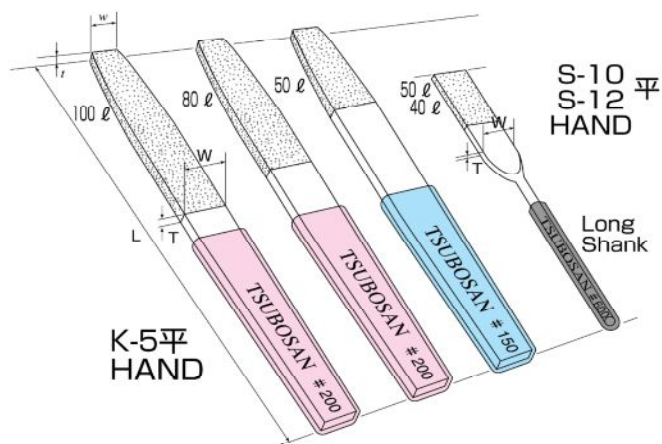

ダイヤモンドテーパースリ DIAMOND TAPERED FORM 426

規格表 STANDARD TABLE

TYPE	DIMENSION	L		W × T mm	w × t mm	BOX pcs	kg-5 pcs	ITEM No.				
		L mm	ℓ mm					#150	#200	#300	#400	#600
K-5	平テーパ HAND TAPER	215	50	11.0×2.0	10.0×0.9	5	0.26	DKHI051T(50)	—	—	—	—
		215	80	11.0×3.0	10.0×0.9	5	0.26	DKHI051T(80)	—	—	—	—
K-8	平テーパ HAND TAPER	200	50	9.0×2.5	8.0×0.7	5	0.19	DKHI081T	DKHI082T	—	—	—
		185	50	7.0×1.8	6.5×0.7	5	0.12	DKHI101T	DKHI102T	—	DKHI104T	DKHI106T
K-10	先細テーパ FLAT TAPER	185	50	7.0×2.0	1.5×0.6	5	0.11	—	DKSH102T	—	—	—
		170	50	4.0×1.8	3.7×0.7	5	0.06	DKHI121T	DKHI122T	—	DKHI124T	DKHI126T
K-12	先細テーパ FLAT TAPER	170	50	4.0×1.4	1.5×0.6	5	0.06	—	DKSH122T	—	DKSH124T	DKSH126T
		極細平テーパ VERY THIN HAND TAPER	170	50	2.5×1.3	2.0×0.4	5	0.02	—	DGHI122T	—	—